

SPECIFICATION	
Number of Circuit	5 amps/circuit(20AWG), 10 amps/circuit(17AWG)
Operating Speed	100rpm continuous
Lead Lengths	500mm
Voltage	Max. 220VDC/VAC
Current Rating	10A 2circuit, 5A 2circuit
Contact Material	Gold to Gold
Lead Size/Type	Silver plated copper Type Teflon Insulated
Noise	100milliohms max

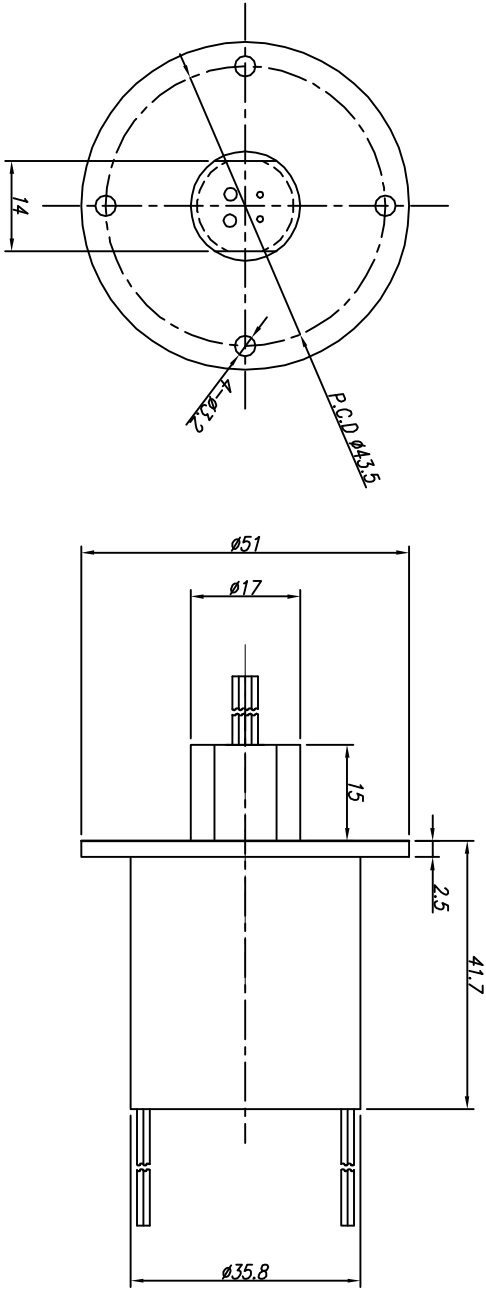

01	WR-SS0202(10A)		MATERIAL		QTY	COATING METHOD	REMARK
NO	PART NAME		DATE		SIZE	PROJECTION	
DRAWING	DESIGN	CHECKED	APPROVE	PRINT SCALE			
LEE.Y.S		KIM.W.B	KIM.W.B	N : S	A3		
				DATE	2017.12.11		
TOLERANCE		0 ~ 10	+0.02	CHAMFER	C = 0.3	DRAWING NO.	
		11 ~ 30	+0.05	FILET	R = 0.3	WR-SS0202(10A)-00-B	
		31 ~ 50	+0.10	ANGLE	±0°20'	1	
		51 ~ 100	+0.15	HOLE PITCH	±0.05	1	
		100 ~	+0.20			1	