

NO.	DESCRIPTION	MAKER	MODEL No.
-----	-------------	-------	-----------

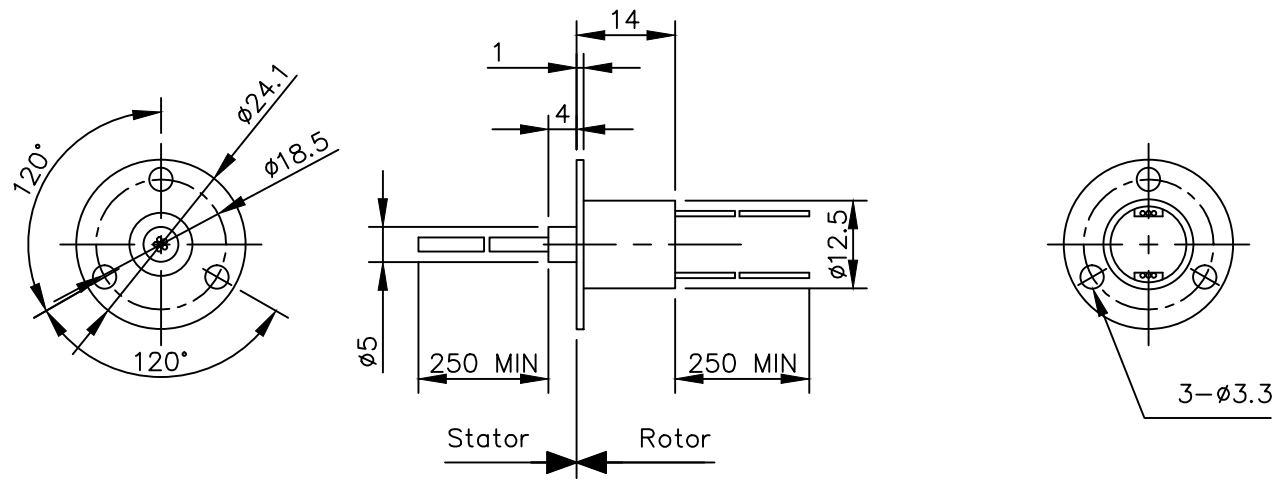

NOTE.

1. Speed : 0-250 RPM
 2. Number of Ring : 6
 3. Voltage : 210VDC & 240VAC
 4. Current : 2Amp per Circuit, Maximum
 5. Contact Material : Gold to Gold
 6. Temperature : -40℃ ~ +80℃
 7. Leadwire : #30 AWG, UL Teflon Wire(Silver Plated Copper)
 8. Rotation : Bi-Directional
 9. Insulation Resistance : 1000 Megohms Min. at 500 VDC
 10. Dielectric Strength : Between each circuit and all other circuits
250VAC @50Hz
 11. Electrical noise : 70 Milliohm Max. tested
@6 VDC, 50 milliamps when running
- @5 rpm

NO.	COLOR
1	검정
2	빨강
3	초록
4	주황
5	파랑
6	백색

01	WR-M006							
NO	PART NAME		MATERIAL	Q'TY	COATING METHOD	REMARK		
DRAWING	DISIGN	CHECKED	APROVE	PRINT SCALE	SIZE	PROJECTION		
LEE.Y.S		KIM.W.B	KIM.W.B	N : S	A3	 우리슬립링		
				DATE	2013.02.04			
TOLERANCE	0 ~ 10	±0.02	CHAMFER	C = 0.3		DRAWING NO. WR-M006-01		
	11 ~ 30	±0.05	FILLET	R = 0.3				
	31 ~ 50	±0.10	ANGLE	±0°20'				
	51 ~ 100	±0.15	HOLE PITCH	±0.05				
	100 ~	±0.20						
						1 / 1		