

NO.	DESCRIPTION	MAKER	MODEL No.
-----	-------------	-------	-----------

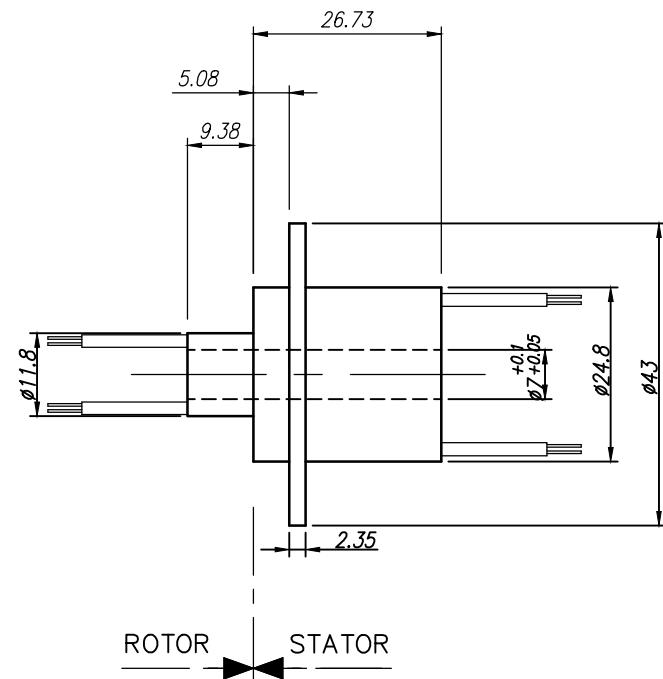
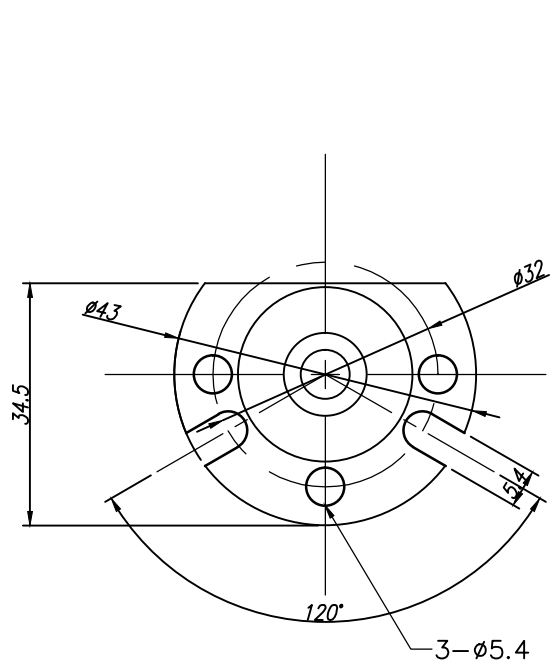

ROTOR      STATOR

SPECIFICATION	
Number of Circuit	2 amps/circuit(28AWG)
Operating Speed	250rpm continuous
Lead Lengths	300mm
Voltage	Max. 240VAC
Current Rating	2A01내 12 circuit
Contact Material	Gold to Gold
Lead Size/Type	Silver plated copper Type Teflon insulated
Electrical Noise	60milliohms max

01	WR-CB012SP						
NO	PART NAME	MATERIAL	Q'TY	COATING METHOD	REMARK		
DRAWING	DISIGN	CHECKED	APROVE	PRINT SCALE	SIZE	PROJECTION	 <b>우리슬립링</b>
LEE.Y.S		KIM.W.B	KIM.W.B	N : S	A3		
				DATE	2015.08.22		
TOLERANCE	0 ~ 10	±0.02	CHAMFER	C = 0.3	DRAWING NO.	WR-CB012SP-01	1 / 1
	11 ~ 30	±0.05	FILLET	R = 0.3			
	31 ~ 50	±0.10	ANGLE	±0°20'			
	51 ~ 100	±0.15	HOLE PITCH	±0.05			
	100 ~	±0.20					